

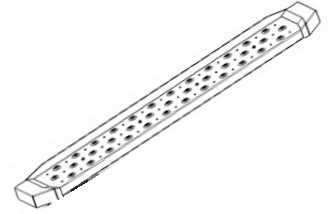

Running Board

Part No. RBW20B



Fits: 2019 1500 SILVERADO REGULAR CAB
EXCLUDES DIESEL W/DEF



60-180 min

Cutting is not Required

Drilling is not Required



REMOVE CONTENTS FROM BOX. VERIFY ALL PARTS ARE PRESENT.



support@trailfx.com



READ INSTRUCTIONS CAREFULLY BEFORE STARTING INSTALLATION.



1 866 638 4870

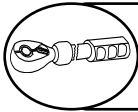

DO NOT OVER TORQUE. STANDARD OPERATING LOAD FOR TIGHTEN BODY MOUNT NUTS & BOLTS VARIES FROM 45 TO 65 FOOT POUND.



POLISHED STAINLESS STEEL - LIMITED LIFETIME
 POWDER COATED BLACK - 3 YEARS

PARTS LIST:

Qty	Part Description	Qty	Part Description
2	Running Boards	4	6mmx 30mm Double Bolt Plates
4	Mounting Brackets	8	6mm x 22mm x 2mm Flat Washers
8	8-1.25mm x 30mm Hex Bolts	8	6mm Lock Washers
8	8mm Lock Washers	8	6mm Hex Nuts
8	8mm x 24mm x 2mm Flat Washers		

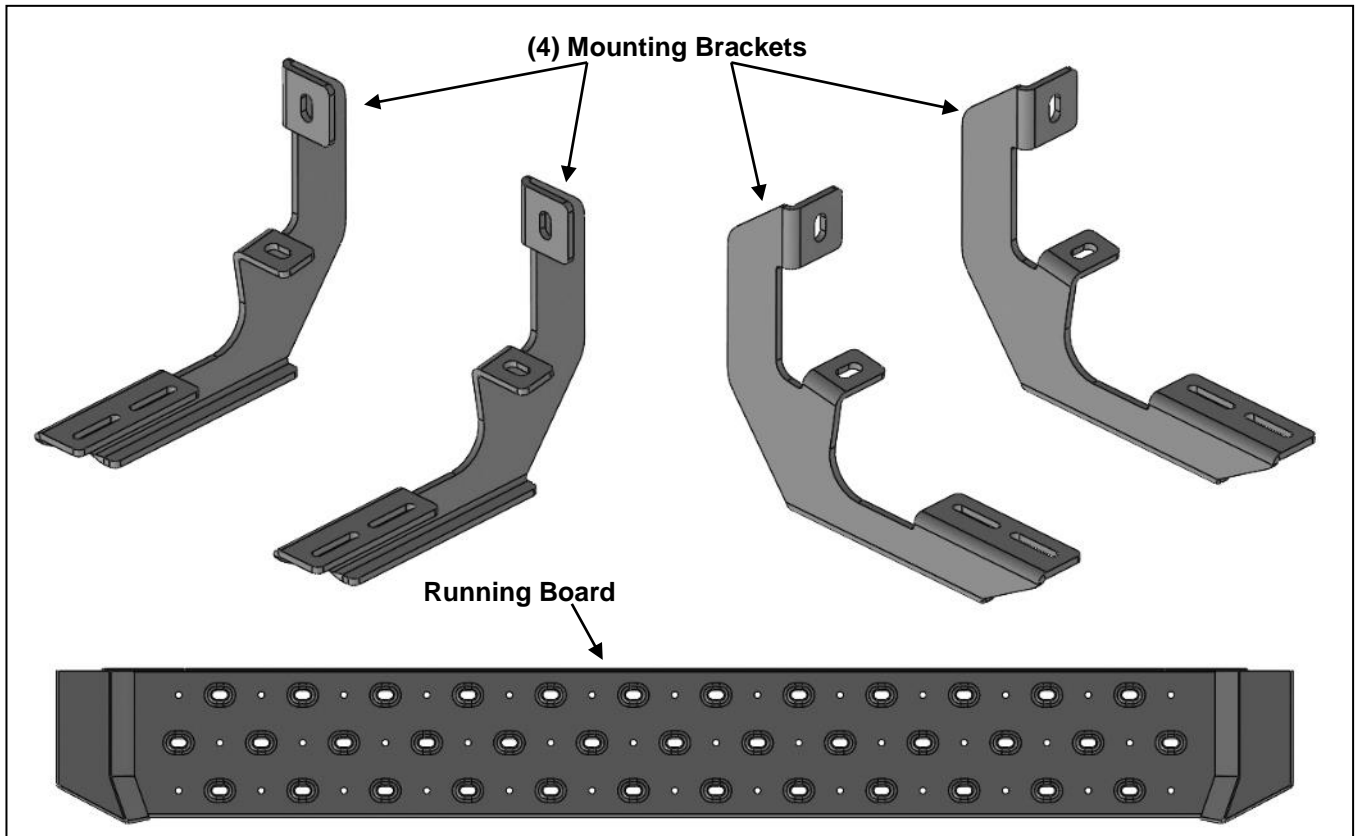

PROCEDURE:

REMOVE CONTENTS FROM BOX. VERIFY ALL PARTS ARE PRESENT. READ INSTRUCTIONS CAREFULLY BEFORE STARTING INSTALLATION. ASSISTANCE IS RECOMMENDED.

1. Start the installation under the Driver/Left side of the vehicle. Locate the plastic plugs along the bottom edge of the body, (**Figure 1**). Mounting Brackets will attach to the threaded mounting holes at the front and rear of the cab. Remove the plastic plugs from the front mounting location. Directly above each threaded insert is a top mounting location on the side of the body panel. Hold a Bracket up in place to help determine the correct mounting holes to use along the body. **NOTE:** Thread an 8mm Hex Bolt into the threaded inserts to clear paint as required.
2. Select (1) Mounting Bracket, (**Figure 2**). Starting at the front of the driver/left side, attach the Mounting Bracket to the factory threaded holes with (2) 8mm x 30mm Hex Bolts, (2) 8mm Lock Washers and (2) 8mm Flat Washers, (**Figures 2 & 3**). Do not fully tighten hardware.
3. Repeat **Steps 1 & 2** to attach (1) Mounting Bracket to the rear mounting location along the body panel, (**Figures 4 & 5**).
4. Select (1) Running Board. Place the Running Board on top of the Brackets. Locate the channel opening in the bottom of the Running Board. Select (2) 6mm Double Bolt Plates. Insert the Bolt Plates into the channel in the bottom of the Running Board closest to the Brackets, (**Figure 6**). Lift the Running Board up and guide the studs through the Brackets.
5. Attach the Running Board to the Brackets with (4) 6mm Flat Washers, (4) 6mm Lock Washers and (4) 6mm Hex Nuts, (**Figure 7**).
6. Level and adjust the Running Board and fully tighten all hardware.
7. Repeat **Steps 1—6** to install the Passenger/Right Running Board.
8. Do periodic inspections to the installation to make sure that all hardware is secure and tight.

To protect your investment, Do not use any type of polish or wax that may contain abrasives that could damage the finish. Mild soap may be used also to clean the Running Board.

Driver/Left side Installation Pictured

Remove plastic plugs to uncover threaded inserts

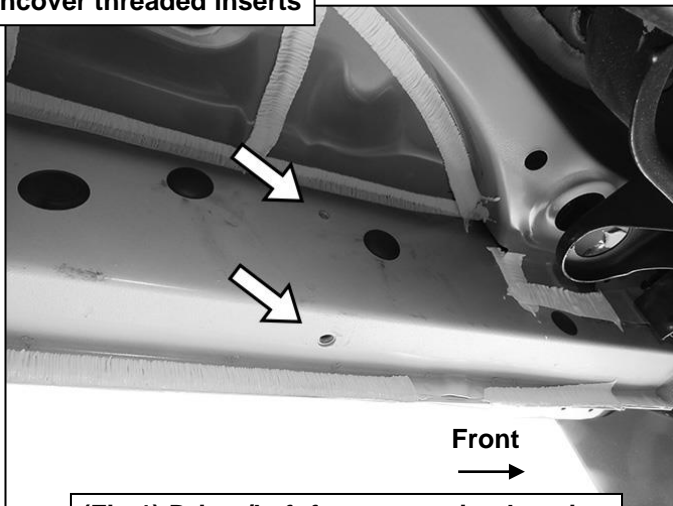

(Fig 1) Driver/Left front mounting location

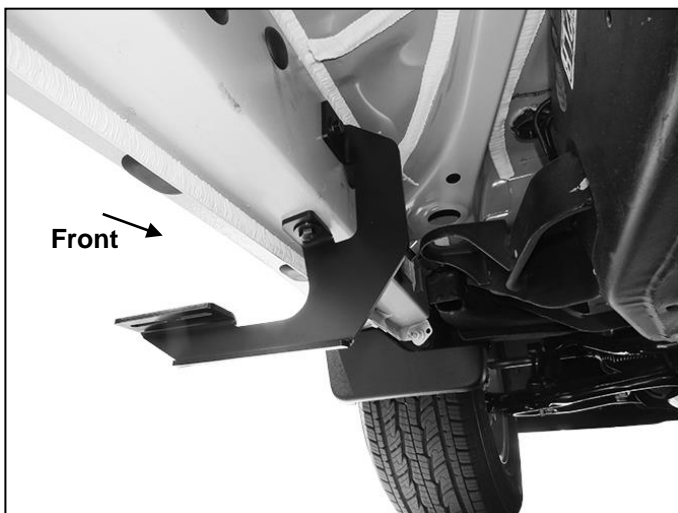

(Fig 3) Driver/Left front Bracket installed

(2) 8mm Hex Bolts
(2) 8mm Lock Washers
(2) 8mm Flat Washers

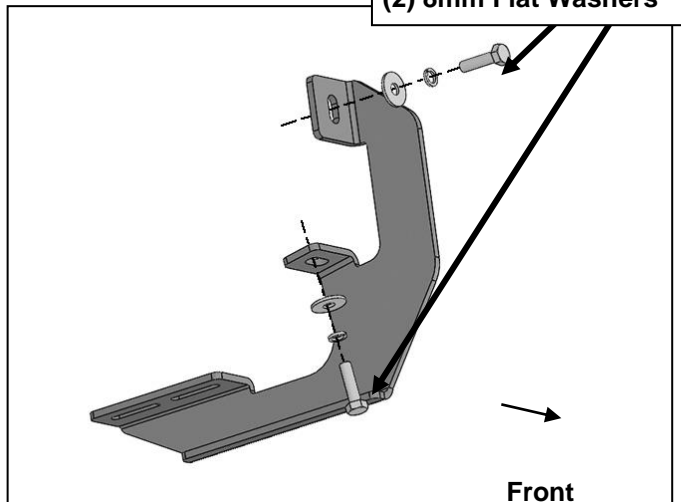

(Fig 2) Mounting Bracket illustration

Driver/Left side Installation Pictured

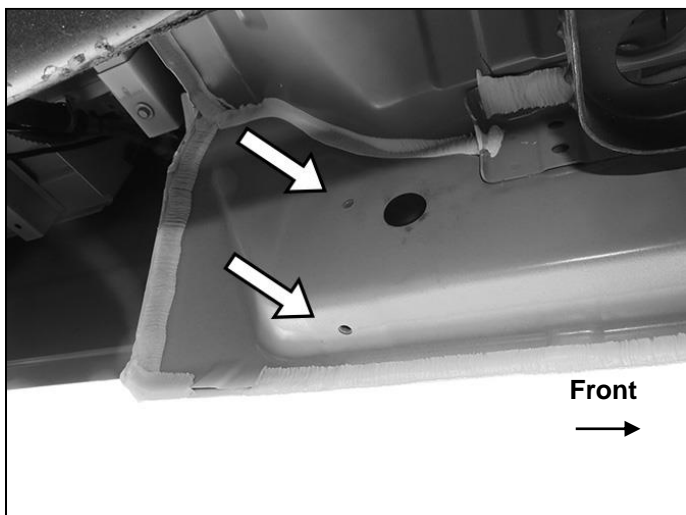

(Fig 4) Driver/Left rear mounting location

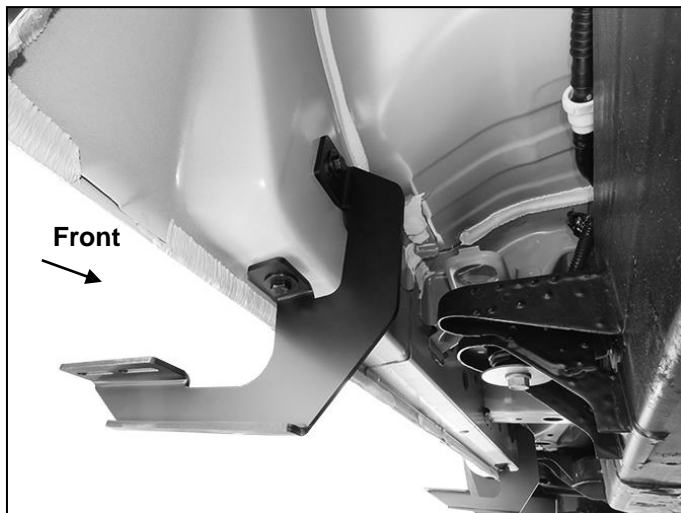

(Fig 5) Driver/Left rear Bracket installed

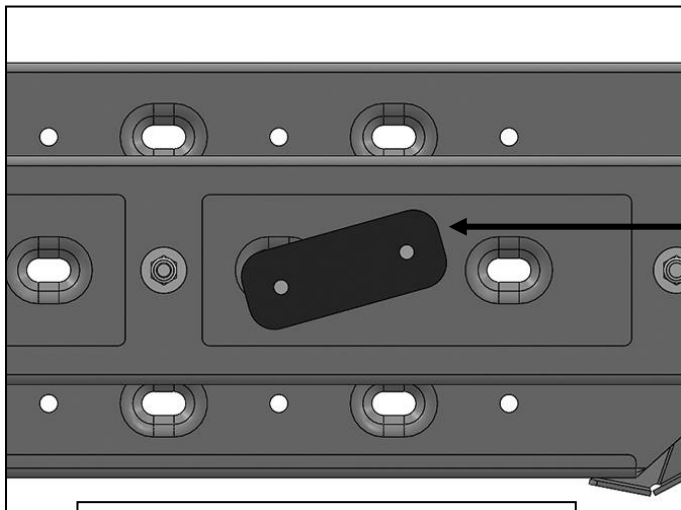

6mm Double Bolt Plate

(Fig 6) Insert Bolt Plate in the bottom of the channel on the Running Board

- (2) 6mm Flat Washers
- (2) 6mm Lock Washers
- (2) 6mm Hex Nuts

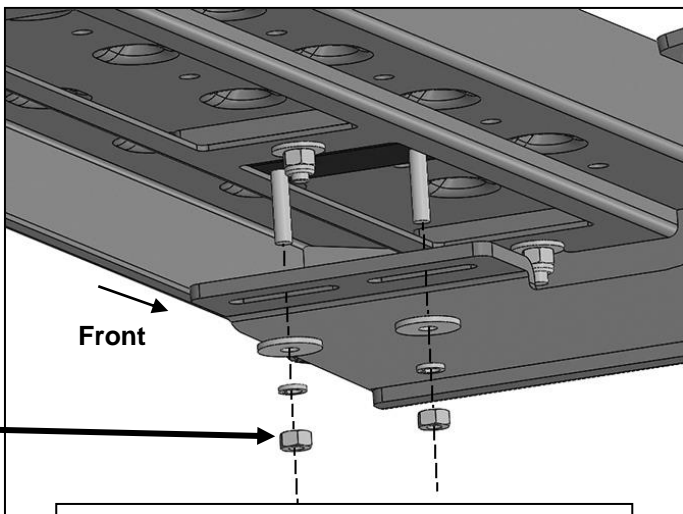

(Fig 7) Attach Running Board to Bolt Plates

PARTS IDENTIFICATION GUIDE

Driver Side tube packed using "Green" color foam sheet. Passenger Side tube packed using "White" color foam sheet

No.	Parts Identification
1	Passenger / Right 'Rear' Bracket marked "PR"
2	Driver / Left 'Rear' Bracket marked "DR"
3	Passenger / Right 'Center' Bracket marked "PC"
4	Driver / Left 'Center' Bracket marked "DC"
5	Passenger / Right 'Front' Bracket marked "PF"
6	Driver / Left 'Front' Bracket marked "DF"

Note:
 > This guide is to identify the parts and not a reference for part count.
 > For part count, refer Parts List.
 > Product / Bracket image is representative and actual design may vary.

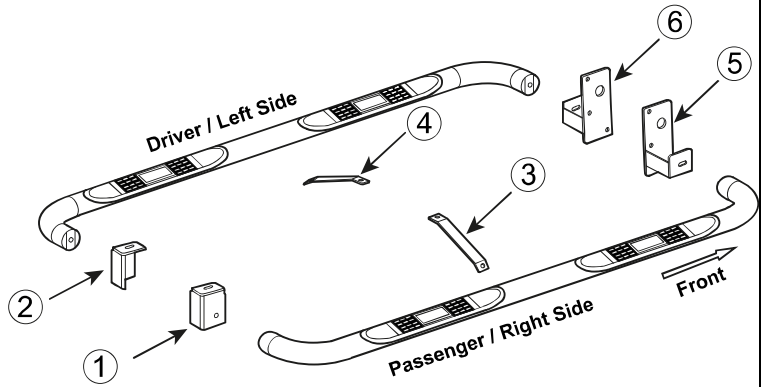

PRODUCT CARE

- Periodically check the product to ensure all fasteners are tight and components are intact.
- Regular waxing is recommended to protect the finish of the product.
- **Use ONLY Non-Abrasive automotive wax.** Use of any soap, polish or wax that contains an abrasive is detrimental and can scratch the finish leading to corrosion.
- Aluminum polish may be used to polish small scratches and scuffs for **Stainless Steel finish.**
- Mild soap may be used to clean the product for both **Stainless Steel and Black finish.**

FAQ's

1. Hardware's are not of correct size.

In GMC / Chevrolet truck model 2006 & up, customer needs to reuse the factory body bolts to install the bracket. If your vehicle is not GMC / Chevrolet 2006 & up, ensure that holes are not partially covered with any plastic grommet or rust? If it is, remove the plastic grommet & rust from the thread holes & re-try the installation.

2. Mounting Bracket are not getting Installed properly.

In some cases Illustration images shown in Installation manual may not be the exactly same as per actual vehicle images ,also if Driver / Passenger side mounting brackets are very identical in the design, suggest referring Parts Identification guide to avoid fitment issue.

3. Products are thumping / rattling after installation.

Ensure that all required mounting brackets / hardware's are installed & tighten correctly. Suggest using white lithium / regular grease between the metal to metal contact surfaces.

4. Side Bar is not aligning with vehicle / Step Pads are not aligning with vehicle doors.

Side bar may be interchanged or mounting brackets are not installed at the correct position in the vehicle. Refer Parts identification guide.

5. Missing / Excess Hardware.

Recheck hardware count as per the part list.

6. Product not installing properly.

Ensure make model year, cab length and bed size of your vehicle is listed in the application. All installation steps are followed correctly.

Check out these other TrailFX Products!!

www.TrailFX.com



Keystone Automotive Operations Inc. (KAO) warrants this product to be free of defects in material and workmanship at the time of purchase by the original retail consumer. KAO disclaims any other warranties, express or implied, including the warranty of fitness for a particular purpose or an intended use. If the product is found to be defective, KAO may replace or repair the product at our option, when the product is returned prepaid, with proof of purchase. Alteration to, improper installation, or misuse of this product voids the warranty. KAO's liability is limited to repair or replacement of products found to be defective, and specifically excludes liability for any incidental or consequential loss or damage.